

sarbak



## TECHNICAL DATA SHEET

CW614N - CuZn39Pb3

S614 - S614DW

RODS / HOLLOW RODS

Product Code	EN Symbol	EN No	ASTM		Cu	Zn	Pb	Sn	Fe	Ni	Al	Si	Others Total
S614	CuZn39Pb3	CW614N	C38500	Min (%)	57,0	Rest	2,5	-	-	-	-	-	-
				Max (%)	59,0	Rest	3,5	0,3	0,3	0,3	0,05	-	0,2
(*)S614DW	CuZn39Pb3-DW	CW614N-DW	C38500	Min (%)	57,0	Rest	2,5	-	-	-	-	-	-
				Max (%)	59,0	Rest	3,5	0,3	0,3	0,2	0,05	0,03	0,2

(\*)Each of the other elements < 0,02 %

### Features And Applications

CW614N called MS58 in the market, is the most widely used standard free machining material with a 100% machinability index. It has got limited hot forming and poor cold forming capability. Also this alloy compliance with RoHS II and REACH directives. CW614N-DW alloy be used suitable for 4MS vs UBA list for drinking water applications. 4MS and UBA Hygienic list group for CW614N-DW alloy: C and D

### Area of Usage

General parts produced by machining.

### Range of Products

S614 and S614-DW alloys can be produced in our extrusion and cold drawing unit as rods, hollows and profiles suitable for both forging and machining. Please contact us for other technical informations.

## TECHNICAL SPECIFICATIONS

Structure	$\alpha+\beta$	Melting Point	880-895 °C
Machinability	% 100	Hot Forming	650-800 °C
Density	8,46 g/cm <sup>3</sup>	Soft Annealing	450-600 °C
Electrical Conductivity	14,6 MS/m, 25 %IACS	Soft Annealing Time	1-3 Hours
Thermal Conductivity	113 W/(m·K)	Stress Relieving	200-300 °C
Elasticity Module	96 GPa	Stress Relieving Time	1-3 Hours
Coeff. of Thermal Expansion	21,4 10 <sup>-6</sup> /K	Max. Depth of Dezincification	-

### INDICATIVE SHAPED ENDS DIMENSIONS

Nominal Diameter or Width		Type A - Chamfer Length (L)		Type B - Point Length (L)	
Across-Flats (mm)		Min (mm)	Max (mm)	Min (mm)	Max (mm)
Over	Up to and including				
7	10	0,2	1,5	2	7
10	20	0,2	2	3	10
20	30	0,2	3	4	12

Unless otherwise specified by the buyer, the shape of the ends of products larger than 30 mm is up to the supplier.

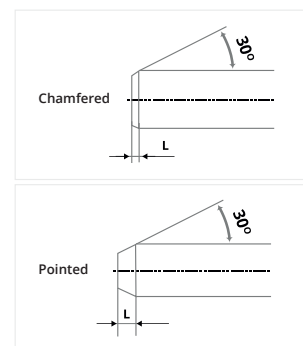



CW614N - CuZn39Pb3

Nominal Diameter or Width Across-flats (mm)		Preferred (available) Lengths (mm)	Tolerance on Length (mm)
Over	Up to and including		
7	30	3.000-4.000	±50
30	65	3.000-4.000	±100

**Stress Relieving** The polygonal rods and hollow rods are subjected to stress relieving treatment  
**Packaging** 500 or 1000 kg bundle – 3/5 metal straps different bundle packagings, up to 10 mm dimension products are packed with wooden case

**EN 12164 - Rods for Free Machining**

Material Condition	Nominal Diameter (mm)		Width Across-Flats (mm)		Tensile Strength Rm N/mm <sup>2</sup> (MPa)	0,2 % Proof Strength N/mm <sup>2</sup> (MPa)		Elongation			Hardness (HBW)		
	Over	Up to and inc	Over	Up to and inc		Min	Min	Max	A100mm (%)	A11,3 (%)	A (%)	Max	Max
									Min	Min	Min		
M	All		All		As manufactured								
R360	7	65	7	55	360	-	350	-	15	20	-	-	
H090	7	65	7	55	-	-	-	-	-	-	90	125	
R430	7	60	7	40	430	220	-	6	8	10	-	-	
H110	7	60	7	40	-	-	-	-	-	-	110	160	
R500	7	14	7	10	500	350	-	-	3	5	-	-	
H135	7	14	7	10	-	-	-	-	-	-	135	-	

**EN 12168 - Hollow Rods for Free Machining**

Material Condition	Wall Thickness (mm)		Tensile Strength Rm N/mm <sup>2</sup> (MPa)	0,2 % Proof Strength N/mm <sup>2</sup> (MPa)		Elongation A (%)	Hardness (HBW)		Hardness (HV)		
	Over	Up to and inc		Min	Min		Max	Min	Max	Min	Max
M	All		As manufactured								
R360	3	40	360	-	320	20	-	-	-	-	
H090	3	40	-	-	-	-	90	125	100	135	
R430	3	15	430	220	-	10	-	-	-	-	
H110	3	15	-	-	-	-	110	160	120	170	
R500	3	7	500	350	-	8	-	-	-	-	
H135	3	7	-	-	-	-	135	-	145	-	

**EN 12165 - Wrought and Unwrought Forging Stocks**

Material Condition	Nominal Diameter (mm)		Hardness (HBW)	
	Over	Up to and inc	Min	Max
M	All		As manufactured	
H080	8	65	80	125

STANDARD		EN 12164			EN 12165		EN 12168				
Dimension Range		Round Rod		Hexagonal, Square	Round Rod		Round and Hexagonal Hollow Rod, Outer Dim. Tol.		Hole Tolerance Round		Hole Tol. Hexagonal
Over	Up to & inc.	Class A	Class B	Rod	Class A	Class B	Class A	Class B	Class A	Class B	-
7	10	0 -0,06	0 -0,036	0 -0,09	±0,25	±0,14	-	-	-	-	-
10	13	0 -0,07	0 -0,043	0 -0,11	±0,25	±0,14	-	-	-	-	-
13	18	0 -0,07	0 -0,043	0 -0,11	±0,25	±0,14	-	-	±0,35	-	+0,70 -0
18	20	0 -0,08	0 -0,052	0 -0,13	±0,30	±0,17	-	-	±0,42	-	+0,84 -0
20	23	0 -0,08	0 -0,052	0 -0,13	±0,30	±0,17	-	0 -0,21	±0,42	±0,17	+0,84 -0
23	26	0 -0,08	0 -0,052	0 -0,13	±0,30	±0,17	-	0 -0,21	±0,42	±0,17	+0,84 -0
26	30	0 -0,08	0 -0,052	0 -0,13	±0,30	±0,17	-	0 -0,21	±0,42	±0,17	+0,84 -0
30	50	0 -0,16	-	0 -0,16	±0,60	±0,20	-	0 -0,25	±0,80	±0,20	+1,6 -0
50	55	0 -0,19	-	0 -0,19	±0,70	±0,37	-	0 -0,46	±0,95	±0,37	-
55	65	0 -0,19	-	-	±0,70	±0,37	±0,60	0 -0,46	±0,95	-	-
65	80	-	-	-	±0,70	-	±0,60	0 -0,46	-	-	-
80	90	-	-	-	±2	-	-	-	-	-	-

### For Hollow Rods

Minimum wall thickness is 3 mm. Eccentricity: %8 (max).

Minimum wall thickness is 5 mm over 65 mm.

**"For hollows, maximum outer diameter is Ø78 mm and maximum producible weight is 28 kg in 1 meter."**

**Outer Cold Drawn - Internal Extruded**

Outer Class B - Hole Class A tolerance

**Inner-Outer Cold Drawn**

Outer Class C - Hole Class B tolerance

**Inner-Outer Extruded**

Outer Class A - Hole Class A tolerance





#### Headquarter

SARBAK METAL TİC. ve SAN. A.Ş.  
Eğitim Mah. Adım Sok. Oran İş Merkezi No: 10 -18 Kat: 3 Daire No: 39 - 49 34722  
Hasanpaşa / Kadıköy / İstanbul / Türkiye  
T: +90 216 414 45 35 pbx | F: +90 216 414 45 40

#### Factory

Çerkezköy Organize Sanayi Bölgesi Gazi Osman Paşa Mah. 8.Cad. No: 3 59500  
Çerkezköy / Tekirdağ / Türkiye  
T: +90 282 725 19 60 pbx | F: +90 282 725 19 70